

## Nuclear power

Contributed by: Frank J. Rahn

Publication year: 2017

### Key Concepts

- Nuclear power is the use of nuclear fusion or, more conventionally, nuclear fission reactions to provide large amounts of energy.
- The release of energy that occurs in a nuclear power reactor, plus the processes associated with this event, constitute the nuclear fuel cycle, which includes fuel preparation, fuel loading and reactor operations, and spent-fuel storage and transportation.
- Fissionable materials are prepared for use in a nuclear reactor through the processes of mining, milling, conversion, enrichment, and fabrication.
- Controlled fission in a nuclear power reactor occurs in a pressure vessel housed in a reactor containment structure. Typically, heat from the fission reaction produces steam, which spins a turbine turning a generator to produce electricity.
- Nuclear power facilities use conservative design margins and redundant safety systems to prevent accidental releases of radiation into the atmosphere.

**Power derived from fission or fusion nuclear reactions.** More conventionally, nuclear power is interpreted as the utilization of the fission reactions in a nuclear power reactor to produce steam for electric power production, for ship propulsion, or for process heat. Fission reactions involve the breakup of the nucleus of high-mass atoms and yield an energy release which is more than a millionfold greater than that obtained from chemical reactions involving the burning of a fuel. Successful control of the nuclear fission reactions utilizes this intensive source of energy. *See also:* NUCLEAR FISSION.

Fission reactions provide intensive sources of energy. For example, the fissioning of an atom of uranium yields about 200 MeV, whereas the oxidation of an atom of carbon releases only 4 eV. On a weight basis, this  $50 \times 10^6$  energy ratio becomes about  $2.5 \times 10^6$ . Uranium consists of several isotopes, only 0.7% of which is uranium-235, the fissionable fuel currently used in reactors. Even with these considerations, including the need to enrich the fuel to several percent uranium-235, the fission reactions are attractive energy sources when coupled with abundant and relatively cheap uranium ore.

## ***Nuclear Fuel Cycle***

Although the main process of nuclear power is the release of energy in the fission process which occurs in the reactor, there are a number of other important processes, such as mining and waste disposal, which both precede and follow fission. Together they constitute the nuclear fuel cycle. (The term cycle may not be exactly appropriate when the cycle is not closed, as is the case at present.) *See also:* NUCLEAR FUEL CYCLE.

The only fissionable material now found in nature is uranium-235. (However, prehistoric natural reactors operated in Gabon, Africa, and possibly also in Colorado in the United States. These produced plutonium that has since decayed to uranium-235.) Plutonium becomes part of the fuel cycle when the fertile material uranium-238 is converted into fissile plutonium-239. Thus, the dominant fuel cycle is the uranium-plutonium cycle. If thorium-232 is used in a reactor to produce fissile uranium-233, another cycle emerges, the thorium-uranium cycle. Since the applications of the latter have been limited to small-scale tests, and a commercial thorium-uranium cycle has not been developed, the discussion below will concentrate on the uranium-plutonium cycle. *See also:* NUCLEAR FUELS; PLUTONIUM; THORIUM; URANIUM.

### **Fuel preparation**

Fissionable materials must be prepared for use in a nuclear reactor through mining, milling, conversion, enrichment, and fabrication.

*Mining.* The nuclear fuel cycle begins with the mining of uranium or thorium. Uranium is estimated to be present in the Earth's crust to the extent of 4 parts per million. The concentration of thorium is nearly three times greater. However, uranium and thorium are so widely distributed that significant concentrations in workable deposits are more the exception than the rule. Exploitable deposits have on average a concentration of 0.1–0.5% of uranium oxide ( $U_3O_8$ ) by weight.

Large deposits of uranium-rich minerals are found in many places: in central Africa and around the gold-mining areas of South Africa, in Canada's Great Bear Lake region in Ontario, and in Australia. Lower-grade ores have been mined extensively on the Colorado Plateau in the United States. There are other deposits being worked in west-central France, in the western mountains of the Czech Republic, in southwestern Hungary, in Gabon, West Africa, and in Madagascar. Also in Africa, rich deposits have been found in the Republic of Niger. Uranium concentration exceeds 15% in a deposit in the Cigar Lake area of Canada.

The chief sources of thorium are coastal sands rich in monazite found at Travancore near the southern tip of India, and on the coast of Brazil. Monazite sands have also been found on the shores of Florida's panhandle.

*Milling.* After uranium ore has been mined, it is crushed and the host rock separated from the core, usually by a flotation process. The uranium is milled and concentrated as a uranium salt, ammonium diuranate, which is generally known in the industry as yellowcake because of its color.

*Conversion.* The yellowcake is then shipped to a conversion plant where it is oxidized to uranium oxide and then is fluorinated to produce the uranium hexafluoride ( $\text{UF}_6$ ). This is a convenient form for the gaseous diffusion enrichment process because the uranium hexafluoride sublimates (passes directly from the solid phase to the gaseous phase without liquefying) at  $127^\circ\text{F}$  ( $53^\circ\text{C}$ ).

*Enrichment.* The uranium hexafluoride, familiarly called hex, is shipped in tanklike containers to one of the three United States gaseous diffusion enrichment plants or to one of several other enrichment plants throughout the world. Gas centrifuges are widely used for enrichment outside the United States. *See also:* ISOTOPE SEPARATION.

After enrichment, the two resulting streams—enriched uranium, and depleted uranium—part company. The depleted uranium is stored adjacent to the diffusion plant, and the enriched material is converted back to an oxide—this time uranium dioxide ( $\text{UO}_2$ )—and sent to a fuel fabrication plant.

*Fabrication.* At these plants, uranium dioxide intended for light-water reactor fuel is shaped into cylindrical pellets about 0.6 in. (15 mm) long and 0.4 in. (10 mm) in diameter. The pellets are sintered, that is, baked, to obtain a hard, dense consistency. After polishing, they are loaded into tubes made of Zircaloy, an alloy of zirconium. A number of tubes are put together with appropriate tie plates, fittings, and spacers to form fuel assemblies. *See also:* ZIRCONIUM.

## Fission in power reactors

From about 1955 to 1965, numerous United States companies explored or planned power reactor product lines, and almost every combination of feasible fuel, coolant, and moderator was suggested.

Power reactors in the United States are the light-water-moderated and -cooled reactors (LWRs), including the pressurized-water reactor (PWR) and the boiling-water reactor (BWR), represent 100% of capacity in operation. The high-temperature gas-cooled reactor (HTGR), and the liquid-metal-cooled fast breeder reactor (LMFBR) have reached a high level of development but are not used for commercial purposes.

Of these concepts, the light-water reactor and the high-temperature gas-cooled reactor are thermal reactors; that is, they operate by using moderated neutrons slowed down to “thermal” velocities (so called because their speed is determined by the thermal, or kinetic, energy of the substance in which the fuel is placed, namely the moderator). The third type, the fast breeder, operates on fast neutrons—unmoderated neutrons that have the high velocities near to those with which they are released from a fissioning nucleus. *See also:* NEUTRON; THERMAL NEUTRONS.

The pressurized-water reactor is in use in France. Canada has developed the CANDU natural-uranium-fueled and heavy-water-moderated and -cooled reactor. The Soviet Union and its successor republics have developed and built considerable numbers of two types of water-cooled reactors. One is a conventional pressurized-water reactor; the other is a tube-type, graphite-moderated reactor.

*Boiling-water reactor (BWR).* In one boiling water reactor, designed to produce about 3580 MW-thermal and 1220 MW net electric power, the reactor vessel is 238 in. (6 m) in inside diameter, 6 in. (15 cm) thick, and about 71 ft (22 m) in height. The active height of the core containing the fuel assemblies is 148 in. (4 m). Each fuel assembly typically contains 63 fuel rods, and 732 fuel assemblies are used. The diameter of the fuel rod is 0.5 in. (12.5 mm). The reactor is controlled by cruciform-shape (in cross section) control rods moving up from the bottom of the reactor in spaces between the fuel assemblies (177 control rods are provided). The water coolant is circulated up through the fuel assemblies by 20 jet pumps at about 70 atm (7 megapascals), and boiling occurs within the core. The steam is fed through four 26-in.-diameter (66-cm) steamlines to the turbine. As is typical for steam power cycles, about one-third of the energy released by fission is converted into mechanical work, and then to electrical energy, by the turbine-generator, and the remaining heat is removed in the condenser. The condenser operates in the same manner in fossil and nuclear power plants, with the heat it removes having to be dissipated to the environment. Some limited use of the energy rejected by the condenser is possible. The steam produced in the plant's nuclear steam supply system will be at lower temperatures and pressures than that from fossil plants, and thus the efficiency of the nuclear plant in producing electric power is somewhat less, leading to somewhat greater heat rejection to the environment per kilowatt-hour produced. *See also:* GENERATOR; STEAM CONDENSER; STEAM TURBINE.

Shielding is provided to reduce radiation levels, and pools of water are used for fuel storage and when access to the core is necessary for fuel transfers. Among the engineered safety features that minimize the consequences of reactor accidents is the primary containment building (**Fig. 1**). The function of the containment building is to cope with the energy released by depressurization of the coolant system should a failure occur in the primary piping, and to provide a secure enclosure to minimize leakage of radioactive material to the surroundings. The boiling-water reactor utilizes a pool of water (called a suppression pool) to condense the steam produced by the depressurization of the primary coolant system. Various arrangements have been used for the suppression pool. Other engineered safety features include the emergency core-cooling system, the containment spray system, and the high-efficiency particulate filters for removing radioactivity from the containment building's atmosphere.

*Pressurized-water reactor (PWR).* Whereas in the boiling-water reactor a direct cycle is used in which steam from the reactor is fed to the turbine, the pressurized-water reactor employs a closed system (**Fig. 2**). The water coolant in the primary system is pumped through the reactor vessel, transporting the heat to a steam generator, and is recirculated in a closed primary system. A separate secondary water system is used on the shell side of the steam generator to produce steam, which is fed to the turbine, condensed, and recycled to the steam generator. A pressurizer is used in the primary system to maintain about 150 atm (15 MPa) pressure to suppress boiling in the primary coolant. Up to four loops have been used.

The reactor pressure vessel is about 44 ft (13.5 m) high and about 15 ft (4.4 m) in inside diameter, and has wall thickness exceeding 8.5 in. (22 cm). The active length of the fuel assemblies may range from 12 to 14 ft (about 4 m), and different configurations are used by the manufacturers. For example, one type of fuel assembly contains 264 fuel rods, and 193 fuel assemblies are used for the 3411-MW-thermal, four-loop plant. The outside diameter

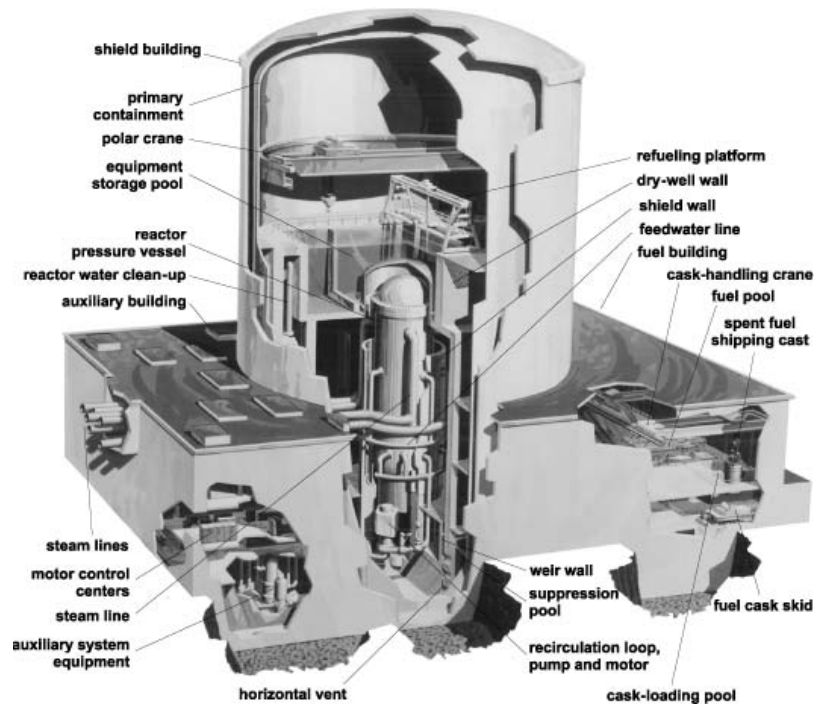

**Fig. 1** Mark III containment building for a boiling-water reactor, which illustrates safety features designed to minimize the consequences of reactor accidents. (General Electric Co.)

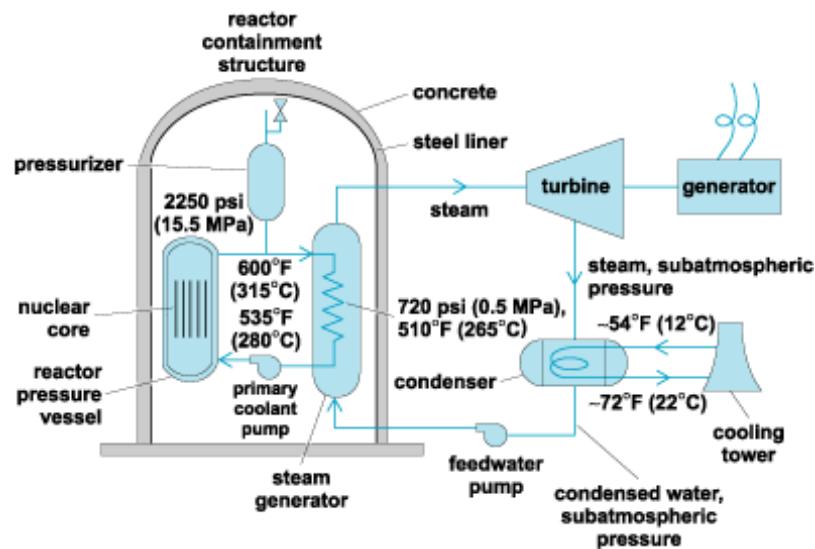

**Fig. 2** Schematic of a pressurized-water reactor power plant. Heat transfer occurs within the containment building. (After F. J. Rahn et al., *A Guide to Nuclear Power Technology*, Krieger Publishing, 1992).

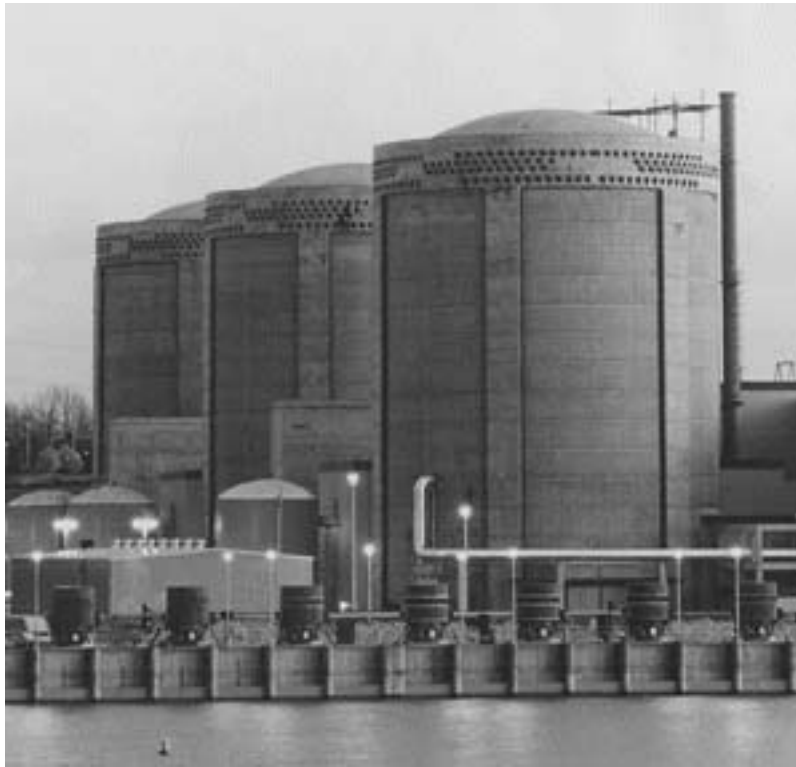

**Fig. 3** Oconee Nuclear Power Station (Greenville, South Carolina) containment structures.

of the fuel rods is 0.4 in. (9.5 mm). For this arrangement, the control rods are grouped in clusters of 24 rods, with 61 clusters provided. In pressurized-water reactors, the control rods enter from the top of the core. Reactor operations are carried out by using both the control rods and a system to increase or decrease the boric acid content of the primary coolant. The latter controls the gross reactivity of the core, while the former allows fine tuning of the nuclear reaction. A typical prestressed concrete containment building (**Fig. 3**) is designed for a 4 atm (400 kilopascals) rise in pressure, with an inside diameter of about 116 ft (35.3 m) and height of 208 ft (64 m). The walls are 45 in. (1.3 m) thick. The containments have cooling and radioactive absorption systems as part of the engineered safety features. Another design (**Fig. 4**) uses a spherical steel containment (about 200 ft, or 60 m, in diameter), surrounded by a reinforced concrete shield building (**Fig. 5**). *See also:* NUCLEAR REACTOR.

*Breeder reactor.* In a breeder reactor, more fissile fuel is generated than is consumed. For example, in the fissioning of uranium-235, the neutrons released by fission are used both to continue the neutron chain reaction which produces the fission and to react with uranium-238 to produce uranium-239. The uranium-239 in turn decays to neptunium-239 and then to plutonium-239. Uranium-238 is called a fertile fuel, and uranium 235, as well as plutonium-239, is a fissile fuel and can be used in nuclear power reactors. The reactions noted can be used to convert most of the uranium-238 to plutonium-239 and thus provide about a 60-fold extension in the available uranium energy source relative to its use in nonbreeder reactors. Breeder power reactors can be used to generate

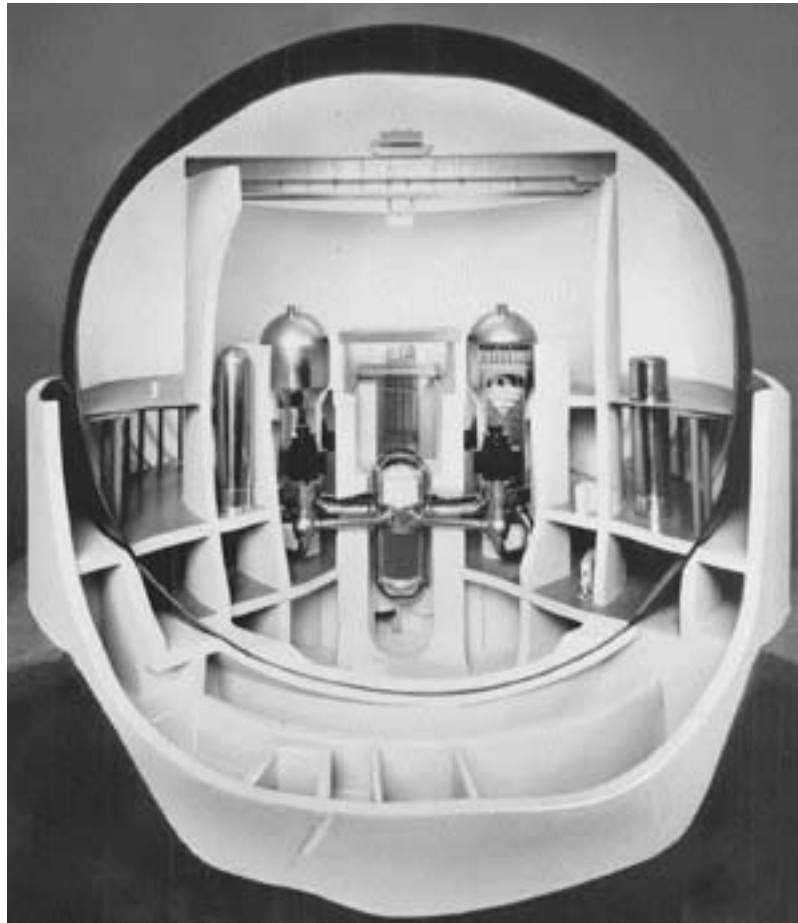
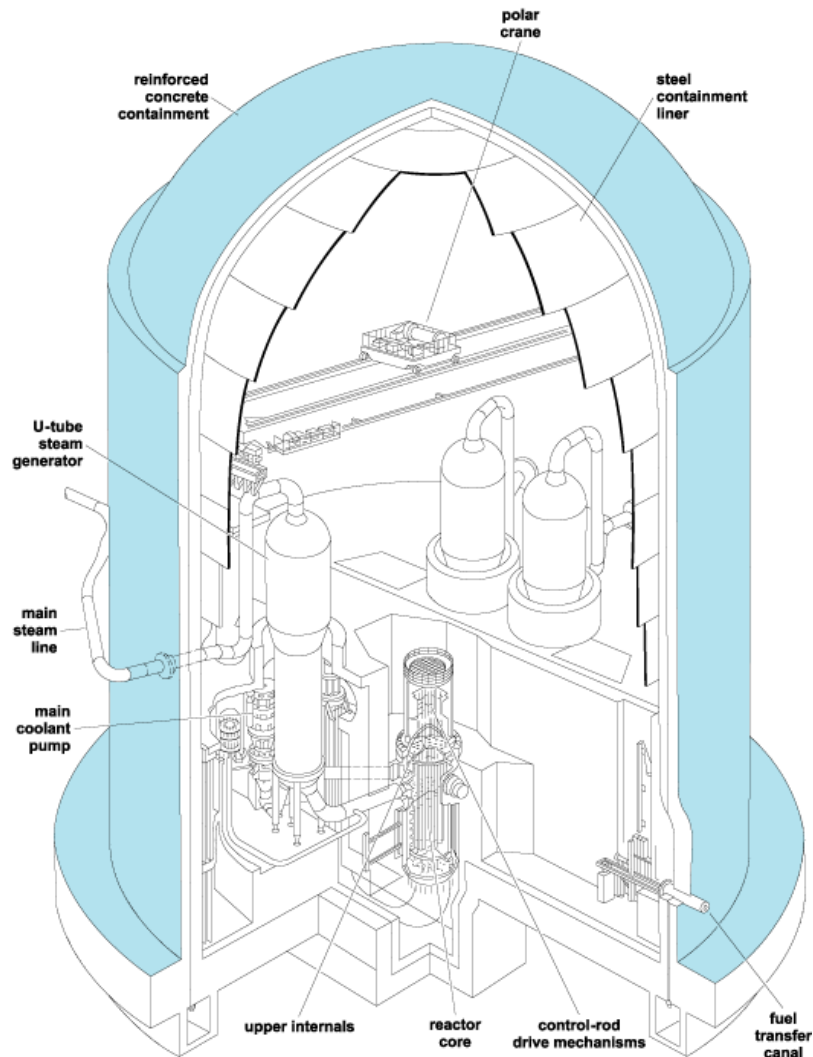

**Fig. 4** Spherical containment design for a pressurized-water reactor. (*Combustion Engineering, Inc.*)

electric power and to produce more fissile fuel. Breeding is also possible by using the fertile material thorium-232, which in turn is converted to the fissile fuel uranium-233. An almost inexhaustible energy source becomes possible with breeder reactors. The use of breeder reactors would decrease the long-range needs for enrichment and for mining more uranium.

Prototype breeder reactors are in use in France, England, Japan, and Russia. A full-scale (1250 MW-electric) commercial breeder, the Super Phenix, was constructed in France and operated commercially between 1986 and 1999.

*Advanced light-water reactor (ALWR).* The most advanced nuclear power reactor designs, referred to as advanced light-water reactors, have evolved from operating experience with light-water reactors. Advanced light-water reactors represent highly engineered designs that emphasize higher reliability, have few components and complex systems, are easier to build and maintain than current reactors, and, in particular, are safer and less sensitive to transients. The higher degree of safety is made possible by the use of redundant, passive systems that



**Fig. 5** Cutaway view of containment building of a typical pressurized-water reactor system. (Westinghouse Electric Corp.)

do not require power for actuation, and the low sensitivity to transients is achieved through low power density in the reactor core and a large inventory of coolant and containment water. Higher reliability depends on the use of systems and components that are proven in service. The designs feature construction periods of as little as 4 years from the start of site excavation, low operating and maintenance costs, long fuel cycles, and simplified maintenance. Excellent fuel-cycle economics are due to high fuel burn-up and a flexible operating cycle. The average occupational radiation dose equivalent is less than 0.5 sievert per year. The plants require increased spent fuel storage to accommodate all the fuel discharged over the plant lifetime.

International participation has been a critical factor in the development of advanced light-water reactors. The **table** summarizes the plants that are offered. Due to the lengthy design, licensing, and prototype development



Advanced light-water reactor (ALWR) designs	
Name	Features
Advanced boiling-water reactor (ABWR)	1300-MW-electric reactor with simplified safety systems, a completely internal recirculation system, and improved controls
System 80+	1350-MW-electric pressurized-water reactor with greater design margins, more redundancy and diversity, and better operability and maintainability
AP-600	600-MW-electric midsize pressurized-water reactor with simplified design and safety features that allow 50% fewer valves, 35% fewer pumps, and 80% less safety-grade piping
SWR-1000	977-MW-electric boiling-water reactor with proven component design, no need for operator intervention in case of accidents, low power density, and 60-year design lifetime
Simplified boiling-water reactor (SBWR)	600-MW-electric midsize reactor employing natural water circulation for power generation, with gravity-driven emergency core cooling from an elevated suppression pool

required for new-generation reactors, the majority of the plants constructed in the period through 2005 are expected to be those in the table.

The first advanced nuclear plant to be constructed was a twin-unit advanced boiling-water reactor (ABWR; **Fig. 6**) at the Kashiwazaki-Kariwa site in Japan. The plant produced power for the electric grid 58 months after groundbreaking. Another advanced reactor concept is the System 80+, under construction in Korea. In 1998, following a 12-year design program, the AP-600 plant became the first advanced light-water reactor to be certified by the U.S. Nuclear Regulatory Commission.

## Fuel loading and reactor operations

Completed fuel assemblies are shipped from the fuel fabrication plant to the power plant in criticality-proof containers and on arrival are stored in a clean fuel vault.

Bolting or unbolting the head of a reactor vessel, to close or open it, is a complex undertaking. A ring of bolts each 2 ft (60 cm) long and 3 in. (8 cm) in diameter is used, with nuts of corresponding magnitude that are fastened in place with mechanical bolt-tighteners. At refueling time, the nuts are removed, and a polar crane at the top of the reactor containment building eases the vessel head off its seating and hoists it to one side onto a pad. The reactor cavity—the concrete pit in which the reactor vessel is moored—is filled with water to a height such that full-length (usually 12 ft or 4 m long) fuel assemblies lifted out of the core can swing clear of the lip of the reactor vessel without coming out of the water. The purpose of the water is to shield the workers from the radiation of the fuel assemblies. Those fuel assemblies removed are lowered into a canal that connects the reactor cavity with the spent-fuel pool by a bridge crane that spans the pool and runs on rails its full length, and as far as the reactor cavity. In this manner, the discharged assemblies are moved to an open position in the racks on the floor of the spent-fuel pool. These racks are made of a metal containing enough neutron poison material to make certain that the spent assemblies in the pool cannot go critical there.

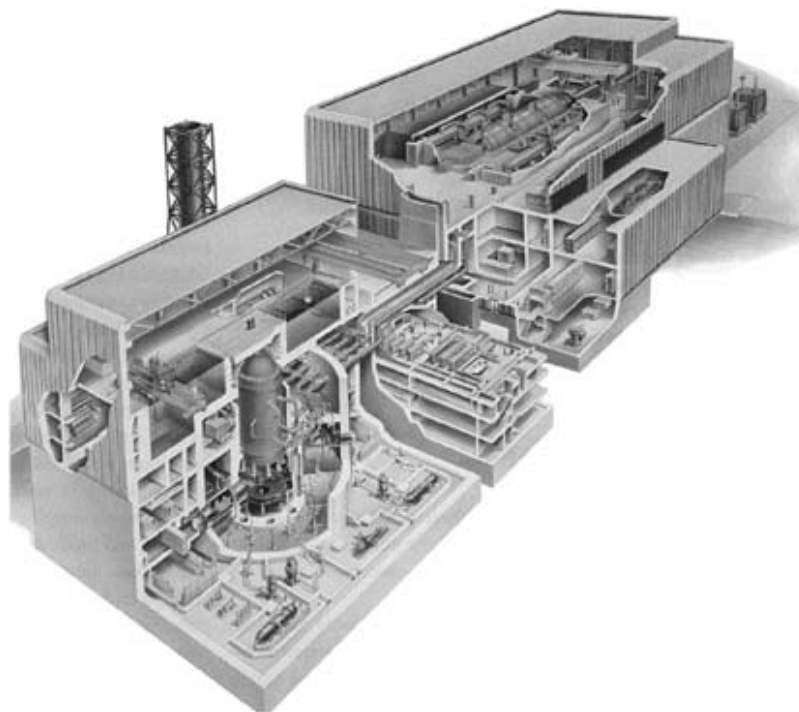

**Fig. 6** Advanced boiling-water reactor (ABWR), the first advanced light-water reactor to be deployed commercially. (General Electric)

The assemblies not ready for discharge are shuffled, that is, their position is rearranged in the core, and the fresh clean assemblies are then loaded into the core grid spaces freed. Underwater periscopes are provided for use in the reactor vessel and in the spent-fuel pool as required. Assemblies discharged are inspected visually by means of these periscopes to check their condition, and a log is kept, recording the serial number of each assembly moved into or out of the core. The radioactive content of the water is also checked to make certain that none of the fuel rods has developed any pinhole leaks that permit release of fission products into the water. *See also:* PERISCOPE.

After the reactor has been “buttoned up” again, that is, the vessel head secured back in place after completion of reloading, the director of reloading operations turns the reactor back to the operating staff for startup. In the process of starting up, a startup source—a neutron emitter—is used as there are not enough spontaneous neutrons emitted to permit close monitoring of the startup process by external neutron detectors. A neutron source (usually an antimony or a polonium-beryllium capsule) which emits a large number of neutrons spontaneously is used for this purpose, and is lowered into the core through a guide tube while the control rods are slowly and carefully retracted.

Radiation monitors around the core report remotely to the control room the neutron flux as it increases. Flux is the number of neutrons crossing a unit area per unit time and is proportional to the fission reaction rate. Once

the reactor has become critical, the control rods are retracted further to increase power until the reactor is at 100% power.

## Spent-fuel storage and transportation

The predominant fueling strategy requires that either one-third or one-fourth of the fuel assemblies be discharged from the core each year. While fresh assemblies are placed in the core to replenish its reactivity, the spent fuel is transferred to an adjacent pool where it is stored for several years. Spent fuel is highly radioactive, and the water serves as shielding and as a cooling medium, to remove the heat produced by the decaying fission products. After several years of cooling in the spent-fuel pool, the assemblies are suitable for transportation to a reprocessing plant. However, this option is not available in the United States, and spent fuel must be stored in the spent-fuel pool at the reactor. Since the amounts of stored fuel increases every year, and because utilities must maintain enough space in the pool for a full core discharge, spent fuel has required changes in storage. These include: redesigning or modifying the pools to allow for denser storage patterns in the same total space available; building more storage capacity at the reactor site; allowing transfers between reactor sites or between utilities to complement needs and available space; and building centralized storage capacity “away from reactor” (AFR) to accommodate the excess quantities. The Department of Energy was required by law to accept spent fuel for permanent storage or disposal, starting in the 1990s, but has not yet done so pending resolution of technical and legal issues.

Transportation of spent nuclear fuel and nuclear wastes has received special attention. With increasing truck and train shipments and increased probabilities for accidents, the protection of the public from radioactive hazards is achieved through regulations and implementation which provide transport packages with multiple barriers to withstand major accidents. For example, the cask used to transport irradiated fuel is designed to withstand severe drop, puncture, fire, and immersion tests. Actual train and truck collision tests have been done to demonstrate the integrity of the casks.

## Reprocessing and refabrication

At the reprocessing center, the spent-fuel rods are stripped of cladding, and the spent-fuel pellets are dropped in a pool of nitric acid in which they dissolve. The solution is then fed to countercurrent extraction systems. Usually, in the first extraction cycle about 99% of the fission waste products are removed. Then further purification and separation of the plutonium from the uranium is performed. The end products of this step are usually uranium dioxide and plutonium dioxide ( $\text{PuO}_2$ ) which can be recycled. The separation is a straightforward chemical process that is carried out by the United States government for weapons material and for spent fuel from nuclear-propelled naval vessels. The reprocessing of commercial fuel is done in order to return the unfissioned fuel material to the inventory of material to be used for fuel fabrication. Commercial nuclear fuel is reprocessed in France, Great Britain, Russia, and on a lesser scale in Belgium, Germany, Japan, India, and Italy. Commercial fuel reprocessing activities were discontinued in the United States in 1976. *See also:* NUCLEAR FUELS REPROCESSING.

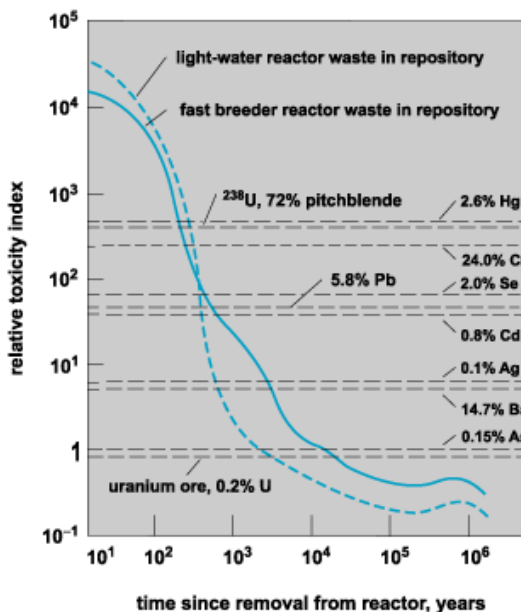

**Fig. 7** Relative toxicity of nuclear waste over time, compared with that of average mineral ores of toxic elements. (After K. A. Tonnessen and J. J. Cohen, *Survey of naturally occurring hazardous materials in deep geologic formations: A perspective on the relative hazard of deep burial of nuclear wastes*, University of California and Lawrence Livermore Laboratories, UCRL-52199, 1977)

## Radioactive waste management

The fission waste products are removed from a reprocessing plant and disposed of in various ways. High-level waste can be concentrated into a glassy bead form, and either buried in salt beds deep in the earth or shipped to a heavily guarded disposal site. Low-level wastes are stored in liquid or solid form.

Critics of nuclear power consider the radioactive wastes generated by the nuclear industry to be too great a burden for society to bear. They argue that since the high-level wastes will contain highly toxic materials with long half-lives, such as a few tenths of one percent of plutonium that was in the irradiated fuel, the safekeeping of these materials must be assured for time periods longer than social orders have existed in the past. Nuclear proponents answer that the time required for isolation is much shorter, since only 500 to 1000 years is needed before the hazard posed by nuclear waste falls below that posed by common natural ore deposits in the environment (**Fig. 7**). The proposed use of bedded salts, for example, found in geologic formations that have prevented access of water and have been undisturbed for millions of years provides one of the options for assurance that safe storage can be engineered. A relatively small area of several hundred acres (a few hundred hectares) would be needed for disposal of projected wastes.

Management of low-level wastes generated by the nuclear energy industry requires use of burial sites for isolation of the wastes while they decay to innocuous levels. Other radioactive wastes, such as those from medical

procedures and industrial applications, equal or exceed these from nuclear power plants. Operation of the commercial burial sites is subject to regulations by federal and state agencies.

Routine operations of nuclear power stations result in very small releases of radioactivity in the gaseous and water effluents. The NRC has adopted the principle that all releases should conform to the “as low as reasonably achievable” (ALARA) standard. ALARA guidance has been extended to other portions of the nuclear fuel cycle.

*See also:* RADIOACTIVE WASTE MANAGEMENT.

## Decommissioning of nuclear plants

There are several light-water reactors in the United States and many light-water reactors and gas-cooled reactors in Europe that have been decommissioned.

Decommissioning requires several steps: assessments and characterization of the hazards, environmental review, engineering, dismantling and decontamination of the plant, and final and remediation. The process requires that the plant be maintained cost-effectively, safely and securely while it awaits decommissioning, and that the site and buildings be made available for reuse following decommissioning (if practical). Some nuclear plants have been considered for conversion to a fossil-fuel power station.

In the United States, there are essentially three options for decommissioning: prompt DECON, delayed DECON, and SAFSTOR. Prompt DECON requires that the equipment, structures, and portions of a facility and site containing radioactive contaminants be removed or decontaminated to a level that permits unrestricted use. Delayed DECON is essentially the same as prompt DECON, but includes a delay for on-site spent fuel storage (usually 10–20 years) to allow sufficient time for the U.S. Department of Energy to develop a spent-fuel repository. SAFSTOR requires that the facility be placed and maintained in a condition that allows it to be safely stored and later decontaminated for unrestricted use, generally within about 60 years of reactor shutdown.

## **Safety**

Nuclear power facilities present a potential hazard rarely encountered with other facilities; that is, radiation. A major health hazard would result if, for instance, a significant fraction of the core inventory of a power reactor were released to the atmosphere. Such a release of radioactivity is clearly unacceptable, and steps are taken to assure it could never happen. These include use of engineered safety systems, various construction and design codes (for example, standards of the American Society for Testing and Materials), regulations on reactor operation, and periodic maintenance and inspection. In the last analysis, however, the ultimate safety of any facility depends on the ability of its designers to use the forces of nature so that a large release of radioactivity is not possible. To help them, various techniques are employed, including conservative design margins, the use of safety equipment, and reliance on various physical barriers to radiation release in case all else fails.

It is the practice, in the United States and elsewhere, for regulatory bodies to establish licensing procedures for nuclear facilities. These procedures set design requirements, construction practices, operational limits, and the siting of such facilities. All power reactors built in the United States (and overseas except in the former Soviet Union) have a containment building and are sited in generally low or moderate population areas with exclusion areas defined by regulation.

All reactors have engineered safety features, both active and passive, designed to prevent serious accidents and mitigate them if they occur. A nuclear plant's safety is achieved through a concept of defense in depth. This provides a series of protective barriers with redundancy at each level and for each active component.

Every reactor has four main barriers to radioactivity release in the event of an accident:

1. *Fuel matrix.* The exceptionally high melting point (5000°F or 2760°C) and chemical stability of uranium dioxide prevent the escape of fission products except in extreme accident conditions. Although the fission process creates large amounts of radioactivity in the fuel rods, the ceramic pellets of uranium dioxide fuel retain more than 98% of this radioactivity. Without fuel melting and subsequent release of fission products, a nuclear reactor accident involves only hazards to the general public comparable with conventional power plant accidents.
2. *Fuel cladding.* The Zircaloy clad surrounding the fuel pellets retains any radioactivity released from the uranium dioxide. Fuel cladding behavior is of importance to the safety of a nuclear plant primarily because the fuel contains the major part of the radioactive products in the plant. The cladding is protected through use of design criteria which limit the heat in the core.
3. *Reactor primary coolant system.* Boundary integrity is assured by the thick steel vessel and piping up to 8 in. (20 cm) thick, and the continual inspection of these components. Licensing requirements specify that the design of the safety systems must accommodate ruptures in the reactor coolant loop, including a break of the largest coolant pipe. This constitutes the design basis for protection against loss-of-coolant accidents.
4. *Reactor containment building.* The reactor containment building generally consists of a 4-ft-thick (1.2-m) concrete shell lined with steel, and is heavily reinforced with steel bars. This steel, embedded in the concrete, gives a reactor containment building great strength to withstand forces that might occur in a reactor accident.  
*See also:* REINFORCED CONCRETE.

Each of these barriers is capable of retaining the hazardous radioactivity contained in a reactor core. Only if all were simultaneously breached would a release to the environment be possible. To prevent breaches, and to attenuate any radioactivity, various other engineered safety features are employed. Their objectives are threefold: shut down the reactor (in the event that the normal control rod mechanisms fail), cool the core (to prevent overheating and meltdown), and safeguard the integrity of the barriers (such as limiting the pressure in a containment building).

Frank J. Rahn

## Test Your Understanding

1. What are the two types of uranium used in fission reactors, and from where are they obtained?
2. What is the main argument against using nuclear power? How do proponents of nuclear power counter this argument?
3. Critical Thinking: Explain the limits to which even the best safety features of nuclear power facilities can fully protect against natural disasters.
4. Critical Thinking: What are potential environmental disadvantages associated with nuclear power plants and with coal-fired power plants?
5. Critical Thinking: Can a nuclear plant explode like a nuclear bomb? Why or why not?

## Bibliography

- S. Glasstone and A. Sesonske, *Nuclear Reactor Engineering*, 2 vols., 4th ed., Chapman and Hall, New York, 1993
- G. F. Hewitt and J. G. Collier, *Introduction to Nuclear Power*, 2d ed., Taylor and Francis, New York, 2000
- R. L. Murray and K. L. Manke, *Understanding Radioactive Waste*, 5th ed., Batelle Press, Columbus, OH, 2003
- F. J. Rahn et al., *A Guide to Nuclear Power Technology*, Wiley, New York, 1984, Krieger, Malabar, FL, reprint 1992
- S. C. Stulz and J. B. Kitto, *Steam: Its Generation and Use*, 40th ed., Babcock & Wilcox Co., New York, 1992

## Additional Readings

- R. M. Harrison and R. R. E. Hester (eds.), *Nuclear Power and the Environment*, The Royal Society of Chemistry, Cambridge, UK, 2011
- K. D. Kok (ed.), *Nuclear Engineering Handbook*, CRC Press, Boca Raton, FL, 2009